

MAGNETIC-BASE SPARE PARTS LIST FOR KARNASCH MAGNETIC HOLE CUTTING MACHINES

ART.: 20 8034 010 TYPE KALP148 - 230 VOLT /
ART.: 20 8034 020 TYPE KALP148 - 110 VOLT



ART.: 20 8034 010 TYPE KALP148 - 230 VOLT /

ART.: 20 8034 020 TYPE KALP148 - 110 VOLT

no	parts list
1	MAGNET BASE
2	MOTOR MOUNT BLOCK
3	BLOCK FIXING BOLTS M6×12 (4)
4	PINION DRIVE
5	M4 RAIL FIXING BOLT
6	M5 RAIL ADJUSTMENT SCREW AND LOCKNUT
7	RAILS (2)
8	ARBOR COMPLETE WITH LOCKING SCREWS AND SPRING
9	ARBOR SUPPORT BRACKET & BEARING
10	SLIDE AND RACK
11	GEARBOX COMPLETE

no	parts list
12	BEARING REMOVAL SCREWS
13	GEARBOX CONNECTING PLATE
14	FUSE HOLDER
15	HANDLE BRACKET
16	HANDLE COMPLETE WITH FIXING BOLT
17	MOTOR UNIT COMPLETE
18	MOTOR NO VOLT SWITCH
19	SWITCH PLATE BOLTS
20	MAGNET/POWER SWITCH
21	SWITCH PLATE
22	M16 CABLE GLAND

no	parts list
24	RIGHT HAND COVER PLATE
25	LEFT HAND COVER PLATE
26	BOTTOM COVER PLATE
27	PCB BOARD
28	INTERNAL SPLINED SHAFT
29	BEVEL GEAR 16T / 29A DRIVE SHAFT
30	BEARING ×2
31	25MM CIRCLIP
32	SPIRAL BEVEL GEAR 24t
33	SPRING/PLUNGER ASSEMBLY
34	RATCHET HANDLE
35	MAINS CABLE
36	GUARD & FIXING SCREWS

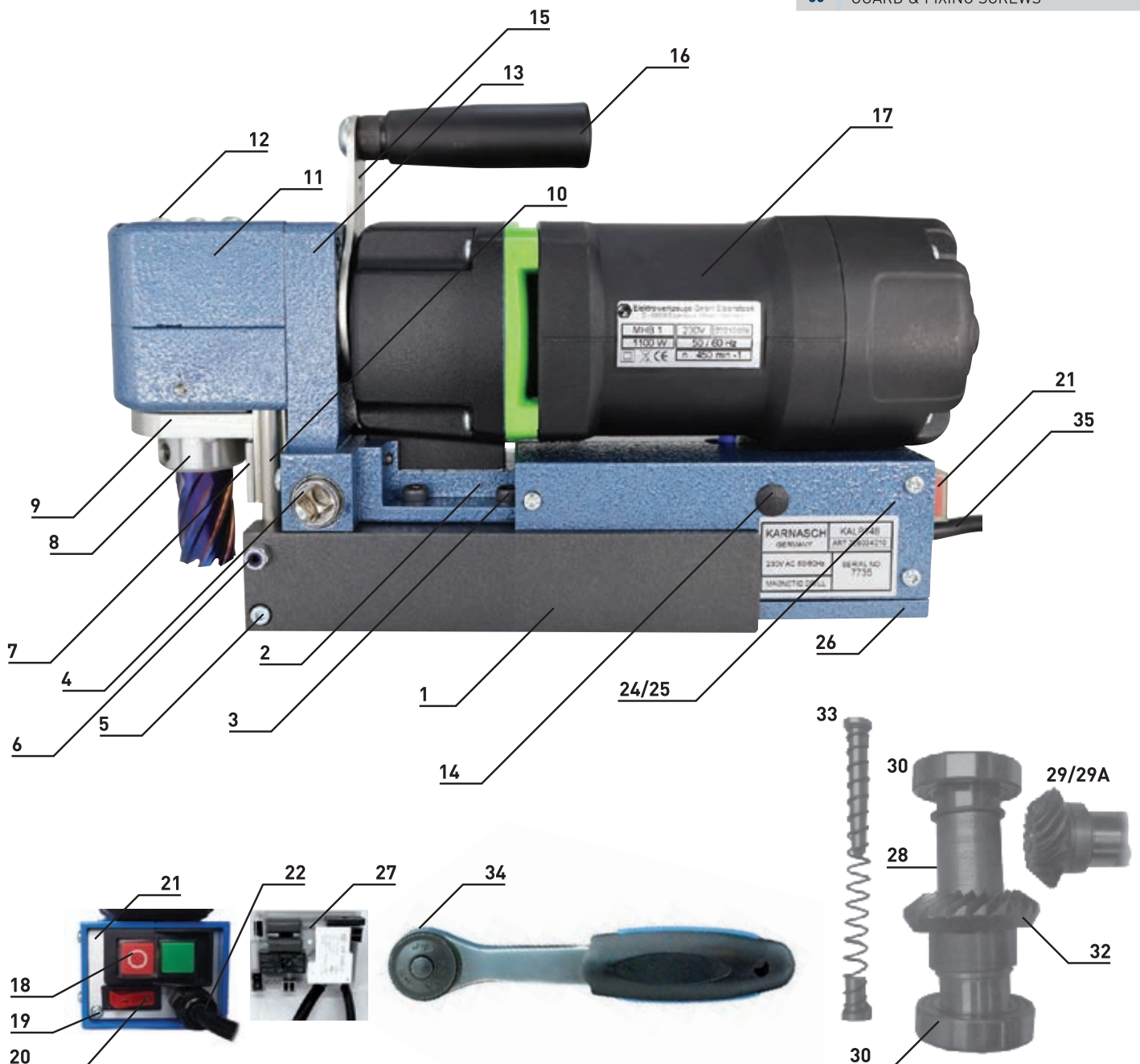

ata Karnasch®

EU Declaration of Conformity

Company: Karnasch Professional Tools GmbH

Address: Theodor-Heuss-Anlage 12, D-68165 Mannheim

Product names: KA35 - KA38 - KA40 - KAS40 - KA50 - KAS50 - KATV55 - KATSV55 - KA100 - KAS100 - KATV100 - KATSV100 - KATV140 - KATV200 - KALP45 - KALP148

Trade name: Karnasch Professional Tools

We, Karnasch Professional Tools GmbH, declare under our sole responsibility that the products to which this declaration relates are in conformity with the essential requirements and other relevant requirements of the Machinery Directive 2006/42/EU, the EMC Directive 2014/30/EU and RoHS Directive 2011/65/EU.

References of applied harmonised standards:

EN IEC 62841-1:2015
EN IEC 62841-2-1:2018 +All:2019
EN IEC 62841-3-13:2017
EN 55014-1:2017 +All:2020
EN 55014-2:1997 +A1:2001 +A2:2008
EN IEC 61000-3-2:2014
EN IEC 61000-3-3:2013
EN IEC 63000:2018

Person authorized to compile the technical file:

Karnasch Professional Tools GmbH, Theodor-Heuss-Anlage 12, D-68165 Mannheim

Place date of issue (of this Doc): Heddeshheim, Germany on 24th August 2022

Signed by or for the manufacture:

Name: Sascha Karnasch
Position: Managing director

KARNASCH PROFESSIONAL TOOLS®

HEADQUARTERS

Theodor-Heuss-Anlage 12
D-68165 Mannheim

KARNASCH PROFESSIONAL TOOLS®

INTERNATIONAL LOGISTIC CENTRE

Straße des Friedens 10
D-15848 Tauche / OT Görzsdorf

CONTACT

Phone: +49 (0) 6203 4039-0

E-Mail: info@atakarnasch.com

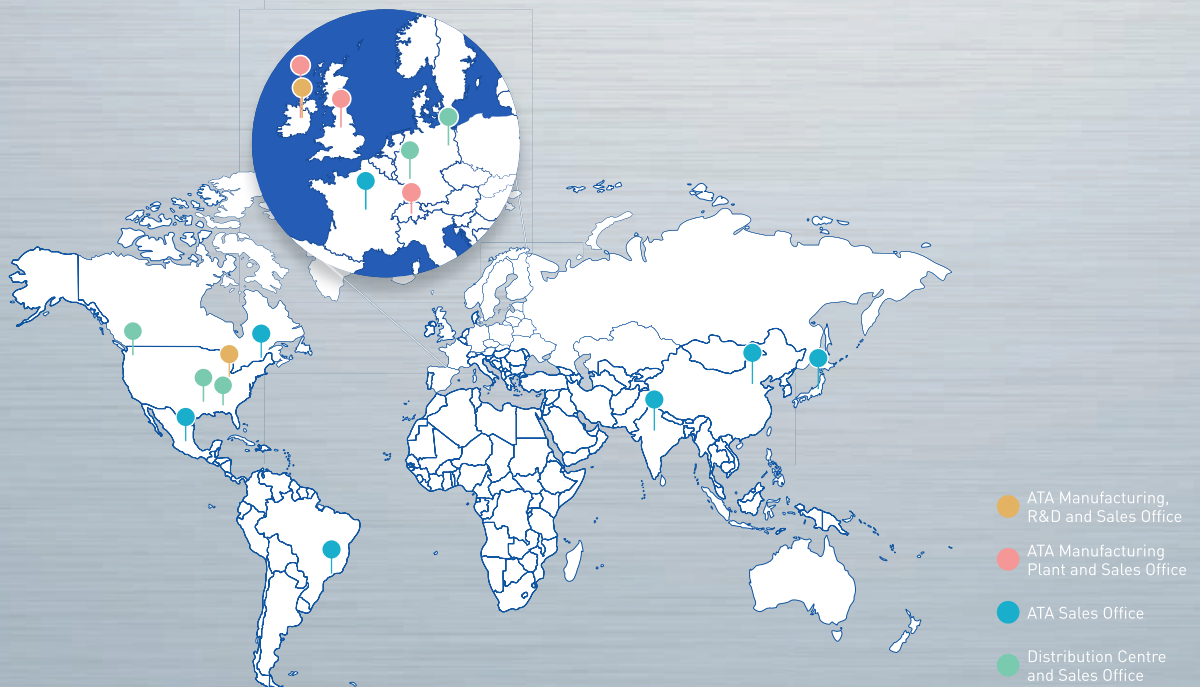

KARNASCH WORLDWIDE

EUROPE AUSTRIA · BELGIUM · BOSNIA HERZEGOVINA · BRITISH VIRGIN ISLANDS · BULGARIA · CROATIA · CYPRUS · CZECH REPUBLIC · DENMARK · ESTONIA · FAROE ISLANDS · FINLAND · FRANCE · GEORGIA · GERMANY · GREECE · HUNGARY · ICELAND · IRELAND · ITALY · KOSOVO · LATVIA · LITHUANIA · LUXEMBOURG · MALTA · MOLDOVA · MONACO · MONTENEGRO · NETHERLANDS · NORWAY · POLAND · PORTUGAL · REPUBLIC OF MOLDOVA · REPUBLIC OF MACEDONIA · ROMANIA · SAN MARINO · SLOVAKIA · SLOVENIA · SPAIN · SWEDEN · SWITZERLAND · TURKEY · UKRAINE · UNITED KINGDOM · **AFRICA** ANGOLA · EGYPT · EQUATORIAL GUINEA · LYBIA · MOROCCO · NIGERIA · REPUBLIC OF MAURITIUS · SAUDI ARABIA · SOUTH AFRICA · UAE/UNITED ARAB EMIRATES · **ASIA** ARMENIA · AZERBAIJAN · CHINA · SOUTH KOREA · GEORGIA · HONG KONG · INDIA · INDONESIA · ISRAEL · JAPAN · JORDAN · KAZAKHSTAN · KUWAIT · LEBANON · MALAYSIA · PHILIPPINES · QATAR · SINGAPORE · TAIWAN · THAILAND · TUNESIEN REPUBLIC · VIETNAM · **SOUTH AMERICA** ARGENTINIA · BRAZIL · CHILE · COLOMBIA · EQUADOR · PERU · **NORTH AMERICA** CANADA · MEXICO · USA · **CENTRAL AMERICA** COSTA RICA · EL SALVADOR · **OCEANIA** AMERICAN SAMOA · AUSTRALIA · NEW CALEDONIA · NEW ZEALAND